

Seduta

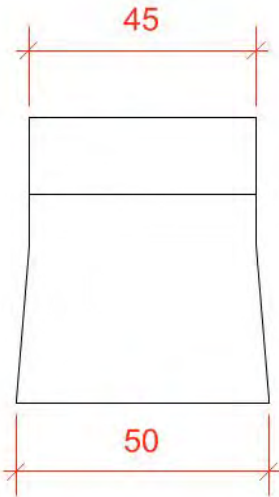

Sedia

Montaggio: 1 minuto

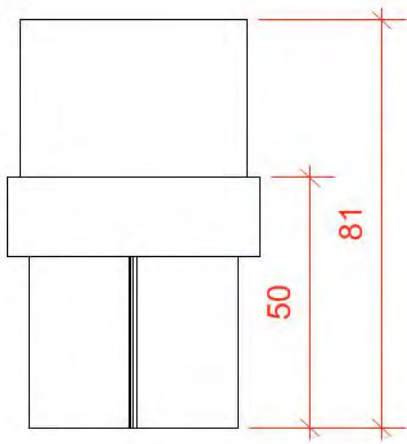
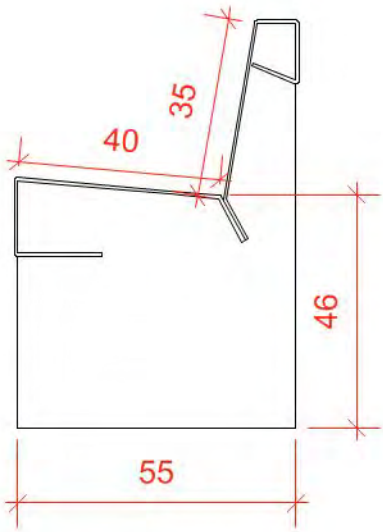
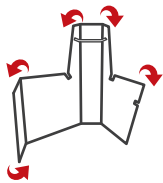

Piegare i lati della gamba più corta verso l'interno

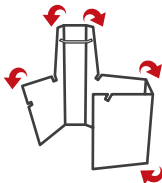

Piegare i lati della gamba più lunga in modo simmetrico rispetto all'altra

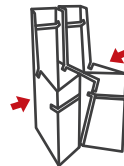

Avvicinare le gambe in modo da far combaciare le punte centrali

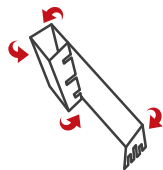

Piegare lo schienale verso l'interno



Piegare la seduta verso l'interno

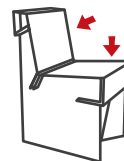

Inserire lo schienale e la seduta nelle fessure delle gambe
